



2019 MINI WEDGE DIVISION RULES

Last Revised: 2019-04-05

Please read the Laird International Raceway General Rules in addition to these Division Rules.

All rules are subject to the discretion of the tech official(s) and track management.

IF IT DOESN'T SAY YOU CAN, YOU CAN'T!

These rules match the 2019 Northern Michigan Speedway Rules & Regulations for the Mini-Wedge division. Thanks to Northern Michigan Speedway.

Rules may be changed by Laird International Raceway when deemed necessary.

Mini Wedge Association Mission:

To provide the safest racing program possible designed to teach young drivers 6-14 years of age the skill, sportsmanship and fair play needed to compete on and off the race track.

Vision:

Laird International Raceway will be a great experience for both parent and child. Opportunities for continuous education and growth will foster personal and career growth. Our efforts will be recognized by others who view us as a benchmark for safety and fairness.

Values:

We must strive to provide a fun and safe environment for every person. We do believe all of our Drivers desire to excel in their life. We must treat each other fairly with respect, plus offer encouragement and appreciation as we work together towards the same goals. To promote families spending good quality time together, at or away from the racetrack

Penalties: If found with modifications to the motor or the restrictor plates or clutch; the first offense will be disqualification for the night and loss of points; the second offense will be disqualification for 2 race nights and loss of all points for the year. A third offence the driver will be suspended for 12 calendar months.

2019 Rules & Regulations:

Car	Section 1
Engine	Section 2
Race Rules	Section 3
Driver Personal Safety	Section 4
Body Drawings / Specs	Section 5
Race Procedure	Section 6

Laird International Raceway encourages a fun, family atmosphere. Times may arise that are stressful and upsetting to both parents and the driver. When addressing these issues, please speak in a manner that is respectful not only to the driver, but to others that are within hearing distance.

Section 1 – Car

Wheelbase 45" – 52". Maximum width of the outside of the tire is 45". There are to be no roofs, sail panels. A maximum of a 3 inch spoiler will be allowed. Spoiler side's maximum height will be 3 inches from deck and 5 inches long.

All karts must be constructed of steel tubing with a complete 6-point roll cage including adequate side protection. Cages must be a minimum of .065 x 1" steel tubing welded to the frame.

The engine must be located behind the driver's seat. No part of the engine can be located beside the seat.

Floor pans are required to be made of steel or minimum .040" aluminum. The floor pans are to be securely bolted or riveted to the frame. The length of the floor pan must go from the center of the seat to the front of the frame going past the driver's pedals.

All karts must have a fully wedge Late Model appearing body. No open fenders will be allowed. There must be at least 4" of body behind the rear wheels. There will be no covered or enclosed motors all motors will remain completely visible at all times. See Body Drawings for more information.

Tires must be a Hoosier (15600 "11 inches tall" or 15500 "10-1/2 inch tall") FK Compound. No grooving or sipping of the tires. No treating or soaking of tires. Tires must durometer 50, any tire that durometer is 48 or less will be deemed has treated and will result in a 12-month suspension.

Rim width cannot be any wider than 6-1/2" wide and must be at least 6" Tall.

Axle must be a Steel Axle and a minimum of 3/16" Wall Thickness Max Length of 38".

No suspension will be allowed. This includes springs, shocks, rubbers, torsion bars and any other type of dampening device.

Rear deck height cannot exceed a maximum of 27.5" from the ground and a minimum of 22" high from the ground.

Rear quarter panel cannot exceed a maximum of 24" and a minimum of 20".

Body must be constructed of .040" aluminum. Plastic may be used for nose, fenders and trim.

No Holes, or Vents in the front Nose or Side Panels

Kart must weigh no less than 355 lbs. with driver Before or after the race. When tracks split the class by age they must split it by 6-9 and 10-14 years old. The 10-14 year old kids must weigh in no less than 375 lbs. with driver after the race.

We highly encourage the doors and quarter panels to be wider than the tires with at the bottom of the doors and quarters to help prevent "Wheel Hop".

At least one vertical D door bar must be welded on each side of the driver running from the main rail to side crash bars for driver protection. See rear side view drawing for more details.

Front and rear bumpers must be mounted at all times. Front and rear bumpers must have at least a 6" tall hoop.

Front and rear down tubes are mandatory for driver's protection.

All tubing on main roll cage must be at least .065" wall tubing.

No Heim Joints are allowed anywhere on the Chassis except for the Steering

Driver's seat must be mounted in four locations (4-Bolts)

Two door numbers must be present with a minimum of 12".

Must at all times have two return springs.

2 Kill switches are required

1- For the Driver

1- Kill switch must be mounted upper top Rear Left Corner of Roll Cage

Any weight mounted on the kart must be painted white with the drivers name and number on the weight. Weight must be mounted by at least a 1/2" bolt. Any weight lost during an event will result of a two week suspension.

5-Point harness system is mandatory. All harness must have a SFI Rated patch.

All karts must have two triangle type side window nets attached to the roll bar one on each side of the driver. If you run the Full Containment seat you are not required to run a window net but are still Highly Recommended.

Arm Restraints are Mandatory and be hooked to the 5 pt Harness. Not the Steering Shaft

Kart Number Must be also at least 4" tall on the rear back of the car. Visible to others drivers to help aid them In lining up

Section 2 – Engine

1 engine will be allowed in 2019. The 6.5 HP (212cc) OHV Predator Engine

Must Run a Green Restrictor (.425)

Engine must remain stock.

Fuel allowed is E85 and regular gasoline

E85 you can change the Jets

Fuel Type Sticker must be visible by motor

NO Alcohol will be allowed

You cannot alter the exhaust in anyway. Cover can be altered to fit the chain guard if needed no taking out the spark resistor for the exhaust.

You can change the spark plug.

You can disconnect the low oil sensor.

You can remove the governor

You can run an ARC Air Cleaner

You cannot change jets When Running Gasoline

NO RACING carburetor

MAX-Torque clutch is the only clutch allowed.

You can run 12, 13 or 14 tooth Clutches.

Engine claim is set to \$125.00 for predator engine anyone finishing the feature can claim any driver at any time that is running a Harbor FRT engine. A LIR official can also swap a motor at any time for a brand new engine. This claim is the engine. Not The Carburetor, Clutch, Chain Guard or Air Cleaner.

This claim is the engine only that does not include the Clutch, Chain Guard or Air Cleaner. The mission is to provide children a safe and competitive series to teach them the fundamentals, sportsmanship and completeness needed to grow into the sport as a young adult. Please keep in mind the Engine / Clutch claim is to give every child the opportunity to compete without the worry of their family not being able to afford it or their family doesn't "cheat" enough to be competitive.

Section 3 – Race Rules

All drivers must be accompanied by a parent or legal guardian. Unless you are appointed his / her legal guardian, by law, you cannot sign a release form for them. Therefore they cannot race. Any exception to this rule cannot be made by an official and must be brought before the track's management or track's insurance carrier for a decision.

Arguing about scoring or judgment calls will not be tolerated. Confrontations / arguments with Officials, track officials or another parent can result in a minimal suspension of 2-weeks from Laird International Raceway

The scoring tower is off limits to drivers and anyone who is not a track staff member.

Any parent, driver, or member of any team involved in any type of confrontation with anyone at the track will result in a suspension of driver and parent or legal guardian for at least two weeks from Laird International Raceway

Age limit is 6-14 years of age. You must provide a copy of your birth certificate before your Registration can be provided.

There will be NO WARNINGS given out for bad behavior such as; No throwing a fit on the racetrack or pit area NO jumping on the track officials, MWA officials, scorers, flagman or track owner. No going to another pit to argue this includes driver, crew and anyone with a Mini Wedge.

Section 4 – Driver Personal Safety

All Drivers Must have a Transponder

All Drivers Must Have a Race Receiver

All drivers must wear an approved SFI – 1 certified or SFI13 – 2A/1 Fire Suit. SFI certification patch shall be required on fire suit.

A Full Face helmet will be mandatory.

All drivers must wear a neck brace.

All drivers must wear arm restraints.

All drivers must wear a closed toe shoe.

Fireproof gloves are mandatory

Section 5 – Body Drawing and Specs

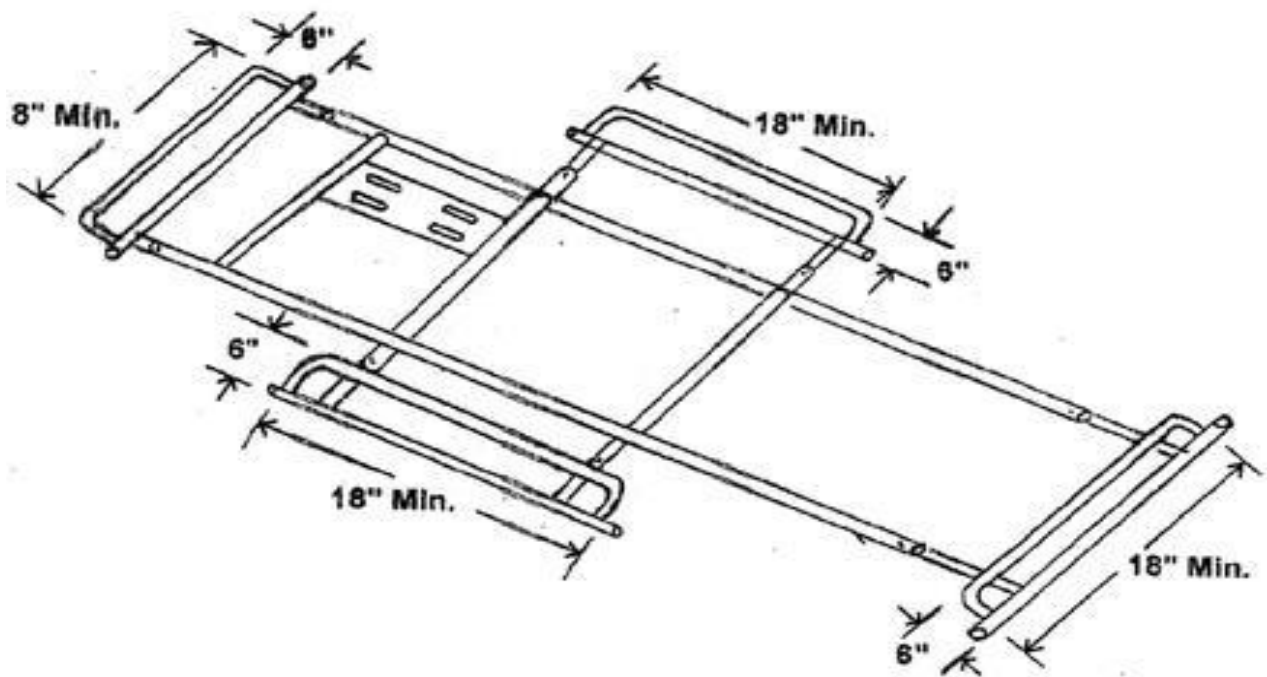
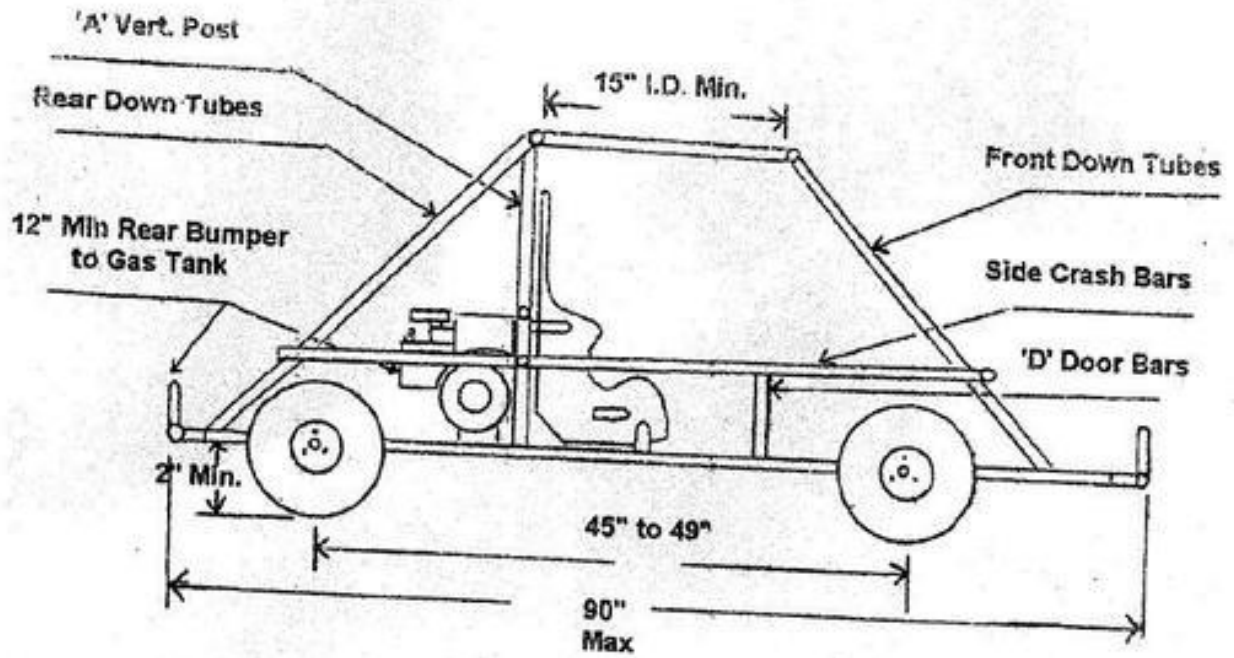

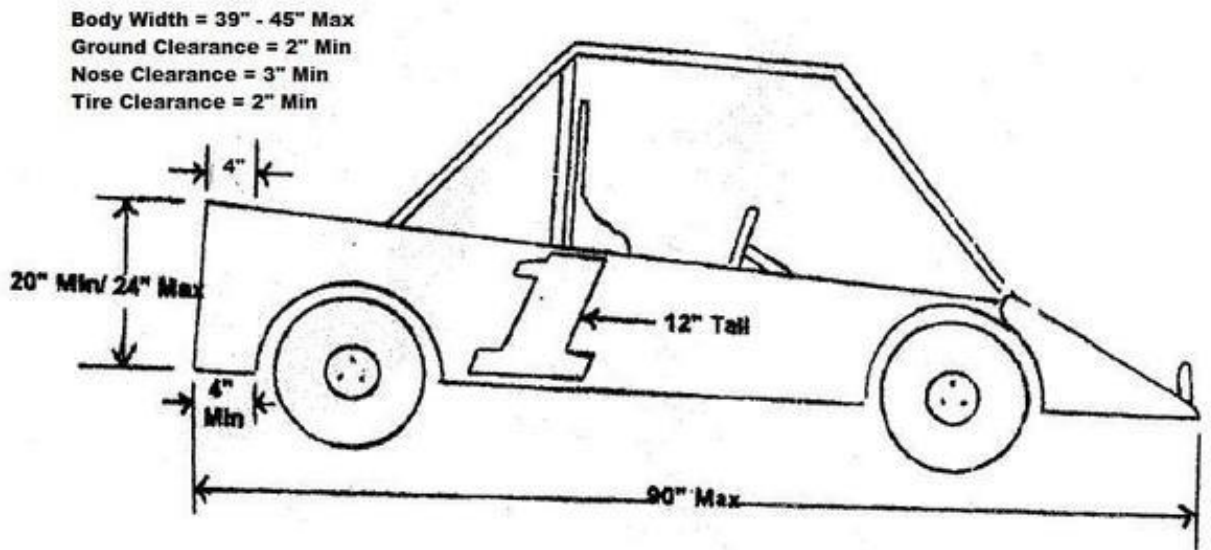

Section 6 – Race Procedure

Cautions will be thrown when a driver spins out and is stopped on the track.

Caution will be thrown when a driver drives off the track and is stuck.

The caution car (judgement call) will be put to the tail.

Two cautions and the driver will be black flagged for that event.

The black flag will be thrown when a driver is driving rough; this is a judgement call and cannot be argued.

The class will be split into two classes when the car count allows. 6 – 9 Year old and 10 – 14 Year old

Race Transponders are Mandatory

Race Receivers are Mandatory

Top 3 will receive a trophy at the end of the night in each class.

Top 3 must report to tech area.